

Perfect torque- constancy for

*Winding equipment
Cap screw applications
Testing machinery
General power transmission*



ROBA[®]-contitorque

*Continuous slip clutch and brake
with the magnetic hysteresis principle*

- *Precise torque limitation*
- *Contactless torque transmission*
- *Wear-resistant and maintenance-free*
- *Load holding*

www.mayr.de[®]

K.150.V04.GB

mayr[®]

your reliable partner

ROBA[®]-contitorque

If you require wear free and reliable torque limitation, the ROBA[®]-contitorque continuous slip clutch and brake is your ideal partner. Contrary to friction type clutches the torque is transmitted contactless via magnetic forces.

Characteristics and advantages of the ROBA[®]-contitorque:

- **contactless torque transmission**
- **accurate torque repetition**
- **precise torque limitation**
- **wear free –
no contamination due to abrasion**
- **maintenance free**
- **load holding**
- **clutch or brake applications**
- **compact design**
- **robust bearing**
- **easy graduated torque adjustment
with direct torque indication**
- **low weight and mass moment
of inertia**

Function with smooth, overload free operation

The ROBA[®]-contitorque synchronously transmits the adjusted torque from an input shaft to an output element, which can be attached to the clutch flange (Fig. 1).

The operational torque T_B is below the limit torque T_g of the clutch (Fig. 2).

The torque is transmitted contactless via magnetic forces, which are generated by permanent magnets, and magnetise a hysteresis material.

Function in case of an overload

If the operational torque T_B exceeds the adjusted limit torque T_g the clutch slips, i.e. input and output components rotate to each other with a relative speed n_s , the so-called slip speed (Fig. 2). The hysteresis material is constantly magnetised and demagnetised and the clutch becomes warm.

The torque is transmitted asynchronously.

The clutch torque T_K also remains on the level of the set limit torque T_g in the case of an overload.

The set limit torque T_g also increases with increasing relative speeds due to eddy-current effects (Fig. 3).

Contact the manufacturer as to exact values for T_g and torque characteristic of the clutch.

After removal of the overload the relative speed n_s returns to zero and the torque is again synchronously transmitted between input and output components.

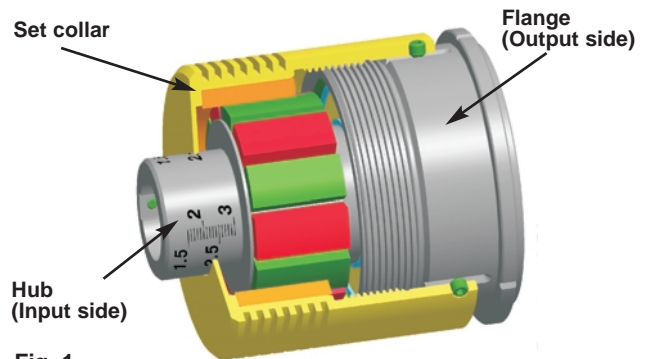

Fig. 1

Clutch torque T_K in case of an overload

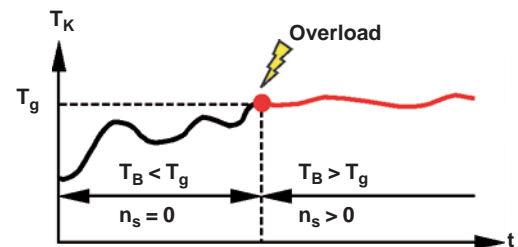

Fig. 2

Torque characteristic

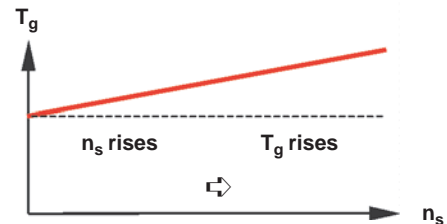

Fig. 3

Torque adjustment

The ROBA[®]-contitorque is characterised by its quick and easy torque adjustment.

If no special torque is defined with the order, the clutch is set to the maximum torque at the factory. The set torque can be determined by means of a hub attached graduation (Figs. 1 and 4).

If the torque requires setting to another value you have to (Fig. 4)

- release the radial setscrews,
- hold the knurled flange and manually turn the set collar until the graduation indicates the required torque value,
- slightly correct the set collar until the marking notches of the flange are axially in line to the setscrews,
- tighten the setscrews again.

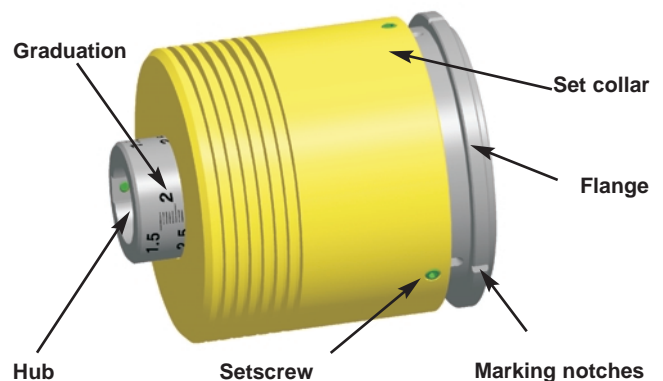
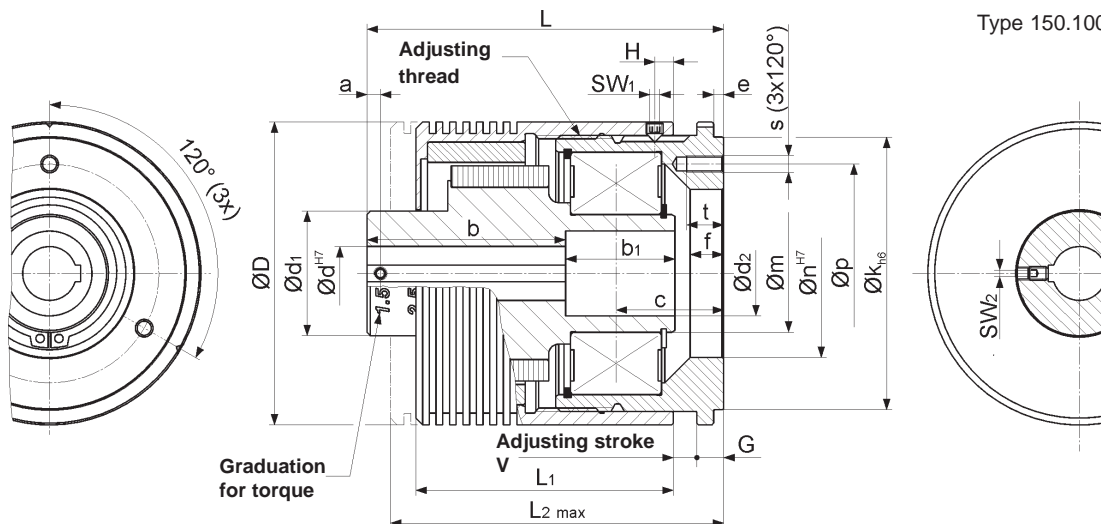

Fig. 4

ROBA[®]-contitorque

Sizes 1 – 4

Type 150.100 + 150.200



Technical data

Size	Limit torque $T_g^{1)}$ for overload		Permissible heat loss $P_{V, perm. [W]}^{2)}$ with an application temperature $^{3)}$ [°C]			Max. permissible mechanical speed $n_{max}^{4)}$ [rpm]	Permissible bearing load $^{5)}$		Weight [kg]	
	Type 150.100 [Nm]	Type 150.200 [Nm]	0 - 25 °C	26 - 35 °C	36 - 45 °C		radial F_{rad} [N]	axial F_{ax} [N]	Type 150.100	Type 150.200
1	0,1 - 0,4	0,4 - 0,8	70	59	48	4000	105	70	0,59	0,69
2	0,1 - 0,8	0,8 - 1,6	79	67	55	3500	220	145	1,28	1,44
3	0,1 - 1,5	1,5 - 3	90	76	62	3000	340	230	1,72	1,97
4	0,2 - 3	3 - 6	122	103	84	3000	560	375	3,04	3,53

Size	Mass moments of inertia [10 ⁻³ kgm ²]								dH7 $^{6)}$ with keyway according to DIN					
	Input side (hub) J_{on}		Output side (flange) J_{off}						6885-1			6885-3		
	Type 150.100	Type 150.200	Type 150.100	Type 150.200	a	b	b_1	c	of	to	over	to		
1	0,034	0,043	0,237	0,27	3,5	45	26	26	10	12	12	14	26	14,2
2	0,165	0,193	0,644	0,735	3,5	53	30,5	30,4	12	17	17	20	31	20,2
3	0,384	0,474	1,31	1,5	4	61	33	33,5	15	22	22	25	37	25,2
4	1,181	1,448	3,725	4,361	4,5	73	37,5	38,9	18	35	35	38	52	38,2

Size	D	e	f	G	H	k_{h6}	L	L_1	L_2_{max}	m	nH7	p	s $^{6)}$	SW $_1$	SW $_2$	t	V
1	62	3	8	7,7	5	54	83	58,5	76,5	20	32	43	M4	2	2	8	0,3 - 10,3
2	77	3	8	7,7	5	69	98	70,5	91,5	30	42	55	M4	2	2	8	0,3 - 13,3
3	90	3	10	7,7	5,5	81	110	80	103	35	50	65	M5	2,5	2	11	0,3 - 15,3
4	113	3	10	8,7	6	103	129	93,5	120,5	50	70	86	M6	2,5	2,5	13	0,3 - 18,3

All dimensions in mm.
We reserve the right to make dimensional and design alterations.
Other sizes for lower and higher torques on request.

- 1) Inquire tolerance values for the maximum deviation of the set limiting torque T_g from the graduation value with the manufacturer. Torque repeatability +/- 2 %. In case of high relative speeds the limit torque T_g increases due to the eddy-current effects. Enquire exact values for T_g with the manufacturer.
- 2) Results in maximum surface temperature of approx. 90 °C with not turning set collar.
- 3) Application temperature in the range of 0 – 45 °C.
- 4) Maximum permissible speed in the slip operation must be calculated via an thermal design (see page 4).
- 5) Related to nominal bearing service life $L_{10h} = 30000$ h, lever arm of the radial force F_{rad} maximum 100 mm distance of centre bearing and bearing speed n_{max} .
- 6) Other mounting dimensions or bores on request.

Type chart – Order example

To be included when ordering, please state:	Size	Type	Bore $\varnothing d$	Keyway to DIN
Order number:		150_00		



* See technical data, limit torque for overload

Example: Order number 1/150.100/12/6885-1; 4/150.200/38/6885-3

Thermal design of the clutch

The ROBA[®]-contitorque slips in case of an overload, i.e. input and output components rotate to each other with a relative speed, the so-called slip speed.

The hysteresis material is constantly magnetised and demagnetised by the magnetic field of the permanent magnets. On that occasion a heat loss occurs, which must be dissipated to the environment in form of a heat.

Otherwise the clutch would overheat and the magnetic material would get damaged.

The heat loss in a continuous slip operation depends on the set clutch torque and the slip speed.

If the clutch is used e.g. with an assembly cycle and only slips a certain part of the complete cycle duration, then the calculated heat loss can be reduced in contrast to the continuous slip operation by means of the reduction factor V.

The following formula is valid for the heat loss:

$$P_V = \frac{T \cdot n_s}{9,55} \cdot V \leq P_{V, \text{perm}}$$

with $V = \frac{t_s}{t_{\text{cycl.}}}$ and t_s 1) $\begin{cases} \leq 30 \text{ s for size 1} \\ \leq 25 \text{ s for size 2} \\ \leq 20 \text{ s for size 3} \\ \leq 15 \text{ s for size 4} \end{cases}$

It applies for continuous slip operation:
V = 1

1) Valid for maximum torque adjustment with type 150.200 and slip speed $n_s = 3\,000 \text{ rpm}$. For other torques and slip speeds inquire values for t_s with the manufacturer.

- P_V = heat loss of the clutch/brake [W]
- $P_{V, \text{perm}}$ = permissible heat loss of the clutch/brake [W]
- T = torque of the clutch/brake [Nm]
- n_s = slip speed [rpm]
- V = reduction factor [-]
- t_s = slipping period [s]
- $t_{\text{cycl.}}$ = cycle period [s]

The following diagram shows the service characteristic of the continuous slip clutch and brake ROBA[®]-contitorque.

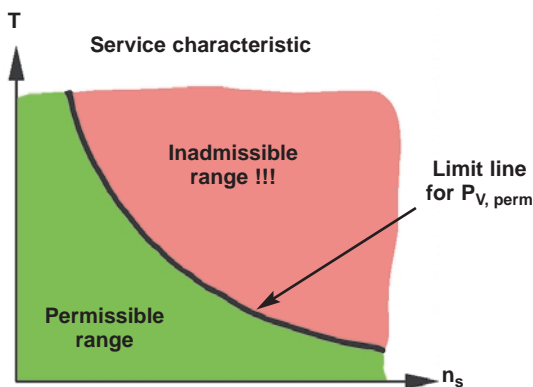

The green range below the limit line of $P_{V, \text{perm}}$ shows the permissible range, with which the continuous slip clutch and brake is not overheated. If the operating point lies in the red range, above the limit line, the clutch overheats and is destroyed.

Design examples

Winding up and off of foil, yarn, wire etc.
(Application as brake in a continuous slip operation)

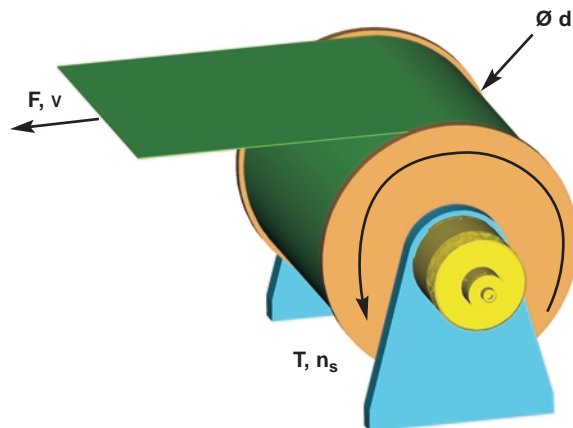

Given:

- F = 20 N Winding tension
- v = 2 m/s Winding speed
- d = 0,2 m Winding diameter roll
- V = 1 [-] Continuous slip operation
- 30 °C Application temperature

Searched:

- T = ??? Torque brake
- n_s = ??? Slip speed brake
- P_V = ??? Heat loss brake

$$T = F \cdot d/2 \rightarrow T = 20 \text{ N} \cdot 0,2 \text{ m}/2 = 2 \text{ Nm}$$

$$v = r \cdot \omega = d/2 \cdot 2 \pi \cdot n_s \rightarrow n_s = \frac{v}{d \cdot \pi}$$

$$n_s = \frac{2 \text{ m/s}}{0,2 \text{ m} \cdot \pi} = 191 \text{ rpm}$$

$$P_V = \frac{T \cdot n_s}{9,55} \cdot V = \frac{2 \text{ Nm} \cdot 191 \text{ rpm} \cdot 1}{9,55} = 40 \text{ W}$$

Selected:

→ ROBA[®]-contitorque, size 3, Type 150.200 with $T_g = 1,5 - 3 \text{ Nm}$ and $P_{V, \text{perm}} = 76 \text{ W} > P_V = 40 \text{ W}$

Screw cap closures

(Application as clutch in an assembly cycle)

Given:

- T = 2,5 Nm Screw cap closure torque
- n_s = 300 rpm Screwing speed
- t_s = 5 s Slipping period
- $t_{\text{cycl.}}$ = 10 s Cycle period
- 40 °C Application temperature

Searched:

- P_V = ??? Heat loss clutch

$$V = \frac{t_s}{t_{\text{cycl.}}} = \frac{5 \text{ s}}{10 \text{ s}} = 0,5$$

$$P_V = \frac{T \cdot n_s}{9,55} \cdot V = \frac{2,5 \text{ Nm} \cdot 300 \text{ rpm} \cdot 0,5}{9,55} = 39,3 \text{ W}$$

Selected:

→ ROBA[®]-contitorque, size 3, Type 150.200 with $T_g = 1,5 - 3 \text{ Nm}$ and $P_{V, \text{perm}} = 62 \text{ W} > P_V = 39,3 \text{ W}$

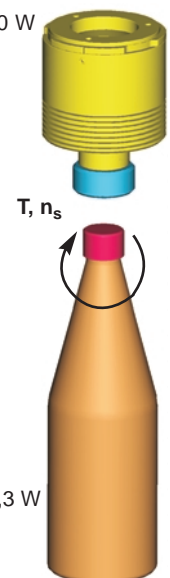

ROBA[®]-contitorque

Safety notes

During operation of the clutch their surfaces can become very hot. In this case direct contact with the clutch is to be avoided, as injuries can occur.

The housing of the clutch is provided with a safety sticker (Caution: hot surface) as standard.

The user can be protected against injuries by additional safety precautions:

- a) Attach signs (Caution: hot surface) in clutch proximity (customer requirement)
- b) Enclose clutch completely (customer requirement)

The clutch must be fitted always in such a way that a direct heat exchange with the environment can take place unhindered (do not raise a build-up of heat by attachment parts). Enclosure must not obstruct any heat exchange.

Assembly and maintenance should only be carried out by well-trained specialists.

Danger of injury exists for persons by the rotary clutch or rotating clutch parts.

The clutch operates with strong magnetic fields. Strong magnetic fields can disturb or damage electronic or mechanical units. This applies in particular to pace makers.

The stored data on credit cards, hard disks or diskettes may also be deleted.

A sufficient safety distance is to be maintained in order to avoid this (greater than 0,2 m).

The clutch must not be exposed to any jerky loads, as the magnets are very hard and brittle and can split on that occasion. In addition the danger exists that impact sparks can develop with jerky loads. Therefore the clutch must not be operated in any explosive atmospheres.

The clutch must not come into contact directly with metal chips, as these are attracted by the magnetic fields, contaminate the clutch and can impair its function. The housing of the clutch must not be dismantled completely, as clutch components are attracted due to the strong magnetic fields and injuries can occur.



- Danger of injury due to hot surfaces



- Danger of injury by compressing the clutch during assembly and disassembly



- Danger for persons fitted with pace makers

Assembly

Shaft attachment

Torque transmission of the clutch at the shaft is made via a key connection.

The clutch can be axially fixed either with a screw and cover (Fig. 4) or with a setscrew (Fig. 5) at the shaft.

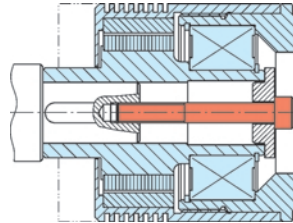

Fig. 4

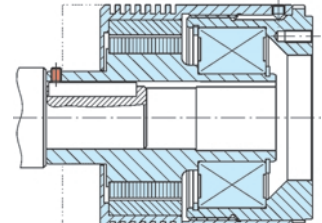

Fig. 5

Output elements (see also mounting examples page 7)

Output elements can be centred on both tolerated diameters of the flange and screwed with the flange.

Dimension table for keyways

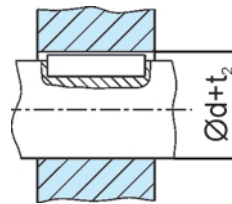

Fig. 6

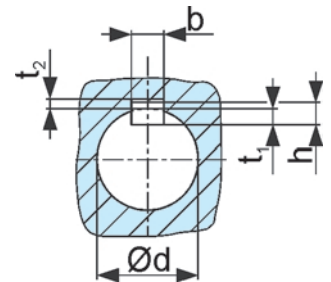

Fig. 7

Diameter d [mm]		according to DIN 6885-1			
		Width b ¹⁾ [mm]	Height h [mm]	Shaft keyway depth t ₁ [mm]	Hub keyway depth d + t ₂ [mm]
above	up to				
8	10	3	3	1,8	d + 1,4
10	12	4	4	2,5	d + 1,8
12	17	5	5	3	d + 2,3
17	22	6	6	3,5	d + 2,8
22	30	8	7	4	d + 3,3
30	38	10	8	5	d + 3,3

Diameter d [mm]		according to DIN 6885-3			
		Width b ²⁾ [mm]	Height h [mm]	Shaft keyway depth t ₁ [mm]	Hub keyway depth d + t ₂ [mm]
above	up to				
12	17	5	3	1,9	d + 1,2
17	22	6	4	2,5	d + 1,6
22	30	8	5	3,1	d + 2,0
30	38	10	6	3,7	d + 2,4

¹⁾ The tolerance of the hub keyway width b is JS 9

²⁾ The tolerance of the hub keyway width b is J 9

Application examples

Screwing technique

- Screwing of various cap closures with a defined torque



Winding up and take off techniques

- Tension force limitation when winding on and off yarns, wires, foils etc.

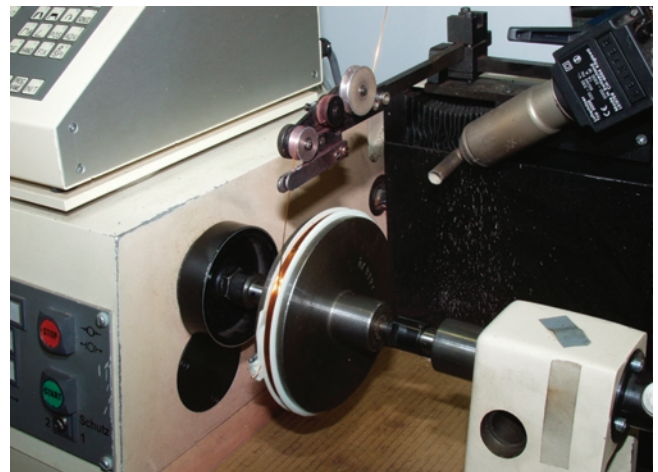

Test stand technique

- Simulation of defined loads

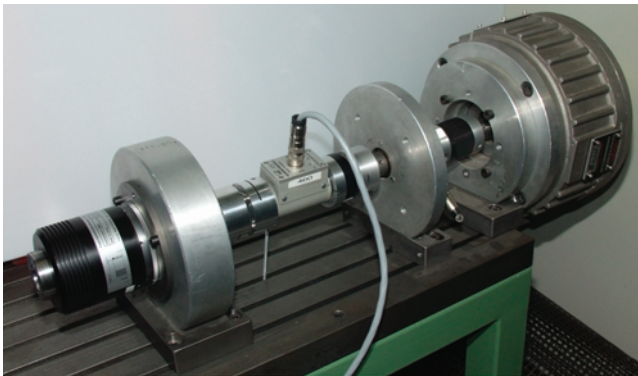

General power transmission

- Torque limitation in split drives



General power transmission

- Torque limitation with polishing machines

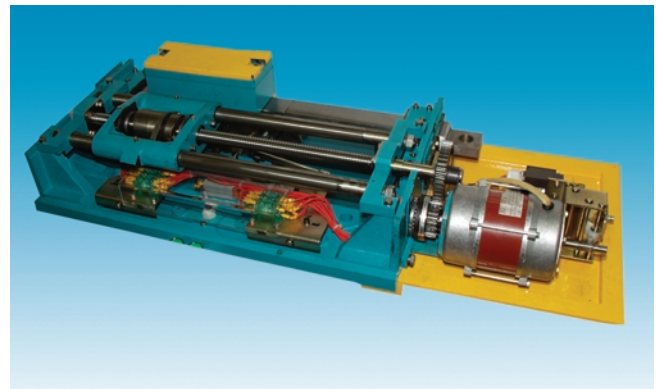

ROBA[®]-contitorque

Installation examples

ROBA[®]-contitorque with attached belt pulley (application as clutch or brake)

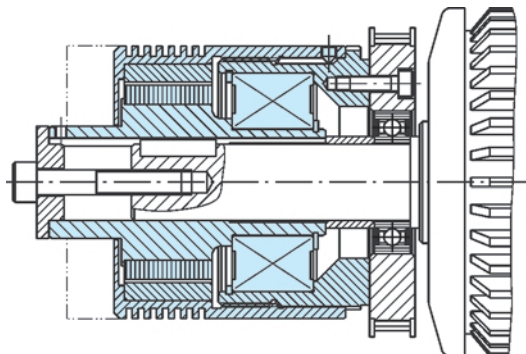

Attachment of the clutch directly on the motor shaft and separate support of the belt pulley by means of a deep groove ball bearing (application as clutch for torque limitation).

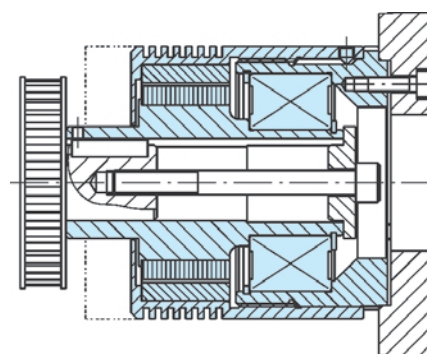

Assembly of the belt pulley directly onto the clutch. The clutch takes over the bearing function for the belt pulley and is rigidly fastened at a machine wall (application as brake for tensile force limitation of a belt pulley).

ROBA[®]-contitorque with winding drum (application as brake)

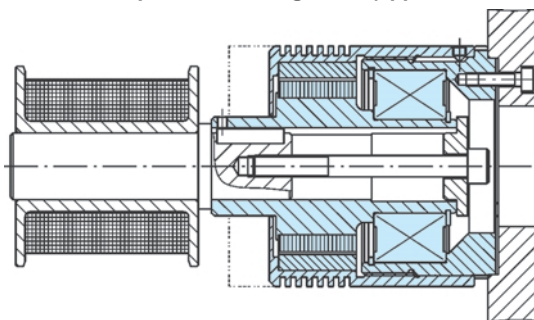

Assembly of the winding drum directly onto the clutch. The clutch takes over the bearing function for the winding drum and is rigidly attached at a machine wall (use as brake for tensile force limitation of the winding unit).

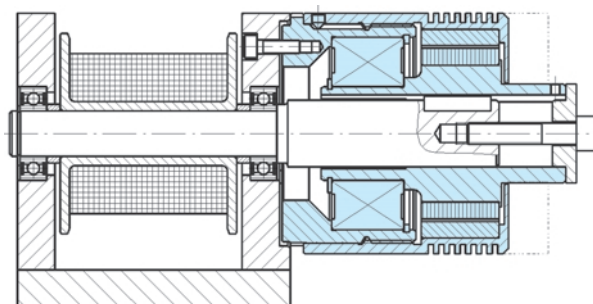

Separate bearing of the winding drum. The clutch does not take over a bearing function and is rigidly fastened at a machine wall (application as brake for tensile force limitation of the winding unit).

ROBA[®]-contitorque with flexible shaft coupling (application as brake)

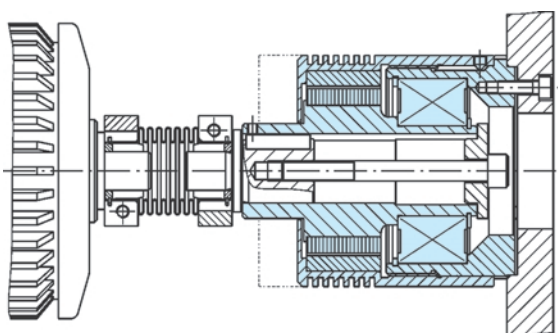

The clutch is rigidly fastened at a machine wall and directly connected with the motor shaft via a flexible shaft coupling (application as brake for an use of the motor with different loads).

ROBA[®]-contitorque (special design) for connection of two shafts in bearing (application as clutch)

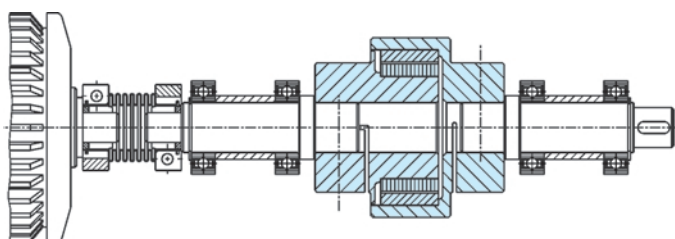

Special design for connection of two separate shafts in bearing. The clutch does not have an own bearing. Both clutch halves are fastened at both shafts by means of clamping hubs (application as clutch for torque limitation).

Worldwide representation

Headquarters

Chr. Mayr
GmbH + Co. KG
Eichenstraße 1
87665 Mauerstetten
Tel.: 49-83 41/8 04-241
Fax: 49-83 41/804422
info@mayr.de
http://www.mayr.de

Great Britain

Mayr Transmissions Ltd.
Valley Road,
Business Park
Keighley, BD21 4LZ
West Yorkshire
Tel.: 0 15 35/66 39 00
Fax: 0 15 35/66 32 61
sales@mayr.co.uk

Italy

Mayr Italia S.r.l.
Viale Veneto, 3
35020 Saonara (PD)
Tel.: 0 49/8 79 10 20
Fax: 0 49/8 79 10 22
info@mayr-italia.it

France

Mayr France S.A.
Z.A.L. du Minopole
BP 16
62160 Bully-Les-Mines
Tel.: 03.21.72.91.91
Fax: 03.21.29.71.77
contact@mayr.fr

Switzerland

Mayr Kupplungen AG
Tobelackerstrasse 11
8212 Neuhausen
am Rheinfall
Tel.: 0 52/6 74 08 70
Fax: 0 52/6 74 08 75
info@mayr.ch

USA

Mayr Corporation
4 North Street
Waldwick
NJ 07463
Tel.: 2 01/4 45-72 10
Fax: 2 01/4 45-80 19
info@mayrcorp.com

Singapore

Mayr Transmission (S)
No. 8 Boon Lay Way
Unit 03-06, TradeHub 31
Singapore 609964
Tel.: 0065/6560 1230
Fax: 0065/6560 1000
info@mayr.com.sg

China

Mayr Shanghai
Room 608, No. 1277
West Zhongshan Road,
Conch Building,
200051 Shanghai, China
Tel.: 021/6295 3138
Fax: 021/6295 3137
sales@mayr.com.cn

Korea

Mayr Korea
60-11, Woongnam-Dong
ROK Changwon
Rep. of Korea
Tel.: 055/262-4024
Fax: 055/262-4025
info@mayrkorea.com

Japan

**Sumitomo HI-PTC
Sales Co., Ltd.**
3-5-8, Kandakaji-Cho,
Chiyoda-Ku
Tokyo J101-0045
Tel.: 03/52563091
Fax: 03/52563098
Gotou.k@sumiju.co.jp

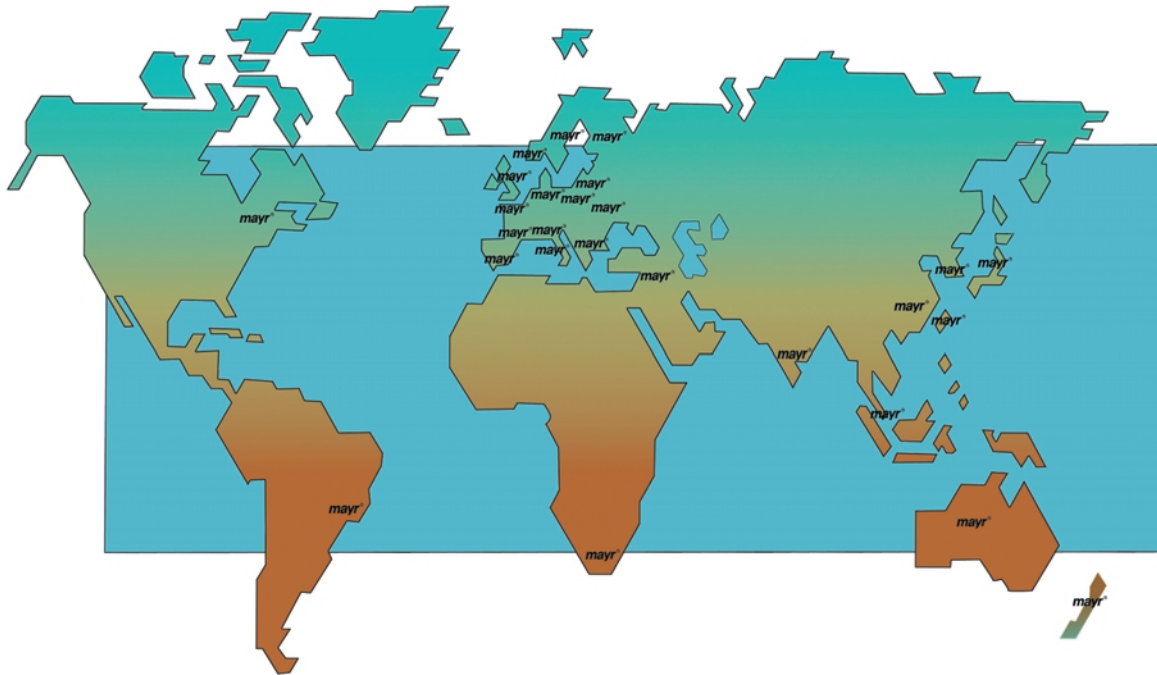

Taiwan

German Tech Auto Co. Ltd.
No. 58, Wu Chuan Road
Wu-Ku Industrial Park
Taipei Hsien, Taiwan
Tel.: 02/22990237
Fax: 02/22990239
steve@zfgta.com.tw

India

National Engineering
Company (NENCO)
J-225, M.I.D.C. Bhosari
Pune 411 026
Tel.: 0202/7 47 45 29
Fax: 0202/7 47 02 29
nenco@vsnl.com

Australia

Transmission Australia Pty. Ltd.
22 Corporate Ave,
3178 Rowville, Victoria
Australien
Tel.: 039/755 4444
Fax: 039/755 4411
info@transaus.com.au

South Africa

Torque Transfer
Private Bag 9
Elandsfontein 1406
Tel.: 011/345 8000
Fax: 011/974 0524
torque@bearings.co.za

**Machine Tool
Applications in China**
DTC. Co.Ltd.,
Block 5th, No. 1699,
East Zhulu Road,
201700 Shanghai, China
Tel.: 021/59883978
Fax: 021/59883979
dtcshanghai@online.sh.cn

Austria
Benelux States
Brazil
Canada
Czech Republic
Denmark
Finland
Greece

Hongkong
Hungary
Indonesia
Israel
Malaysia
New Zealand
Norway
Philippines

Poland
Romania
Russia
Slovakia
Slovenia
Spain
Sweden
Thailand

Turkey

Note:
If a country is not
shown, please refer
to headquarters or
our web site to be
advised of the
nearest responsible
agent.